

300-500 kW

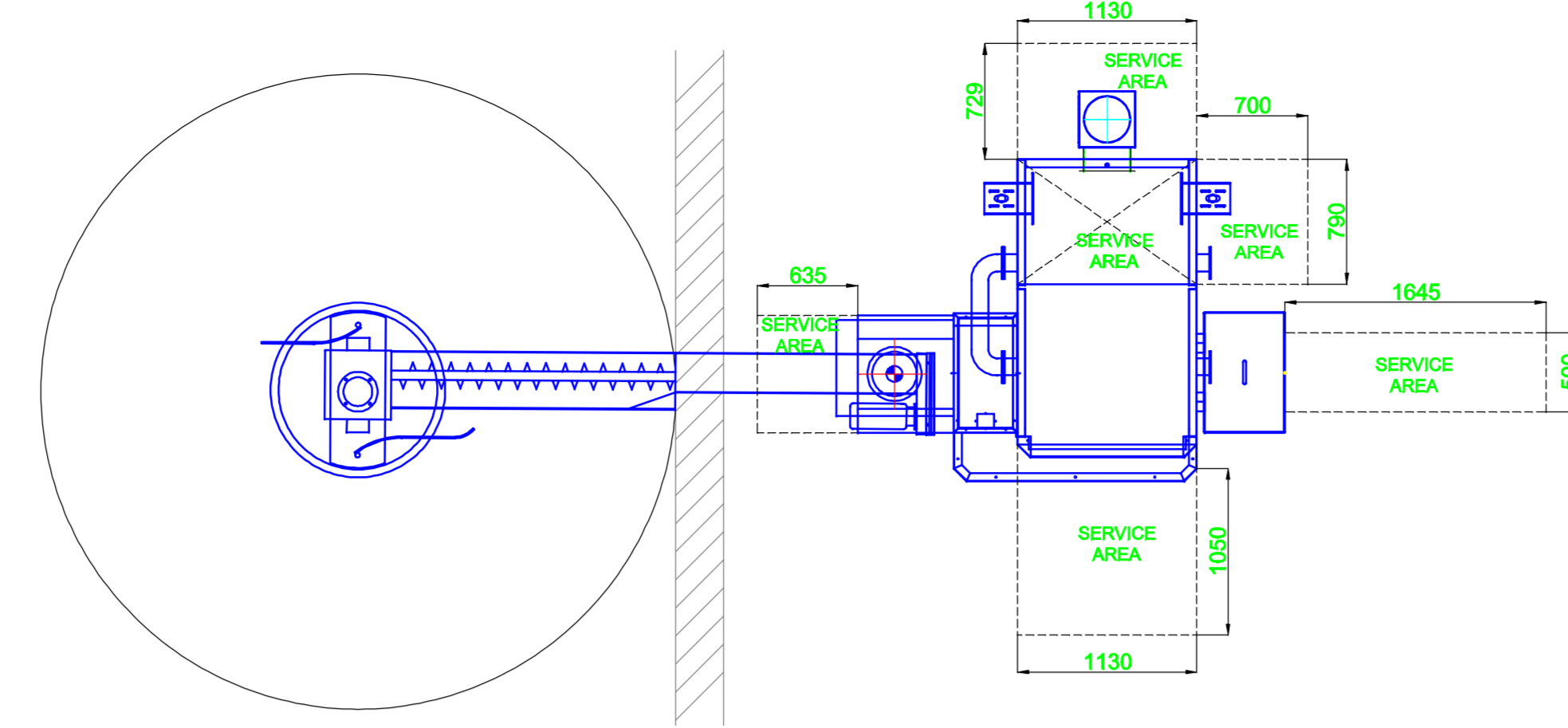

150-500 kW

